

# TECHNICAL & ESD FURNITURE ANTISTATIC EQUIPMENT

catalog  
2015  
UK

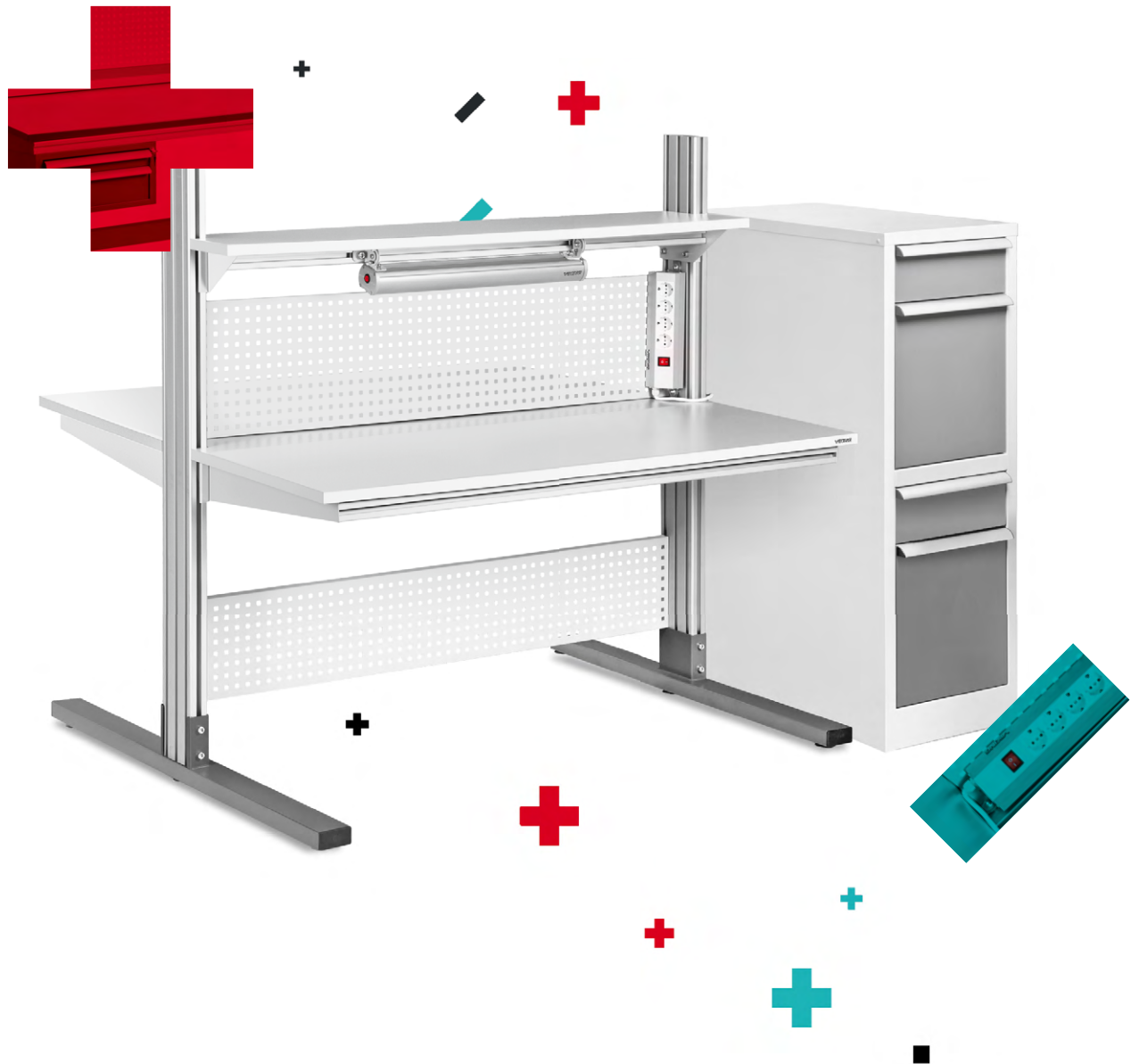

**VIKING VKG TOOLS**



## ABOUT US

By 2014 DIPAUL group have accumulated over 20 years of significant experience in electronics and semiconductor industries market, offering solutions, technologies and equipment. In the course of these years some major companies from military-industrial and aerospace sectors, contract manufacturers, research and educational organizations, service and repair providers, telecommunication operators and other enterprises have become our clients.

Over 10 years ago, understanding all our clients' needs and requirements, we started manufacturing workplaces for electronics devices assembly under VIKING brand. We were the first in Russia to develop new technologies and use new materials to manufacture antistatic furniture, which complies with international IEC 61340. By now we became a leading Russian producer of ESD workbenches, storage units and additional equipment for electronic industry. VIKING ESD workbenches and other products have practically become a top standard for Russian radio electronics companies. Dipaul group has implemented dozens of equipping projects for such Russian companies as Transneft, Gazprom, Rosenergoatom, Russian Space Systems and international companies like Samsung Electronics, LG Electronics, Volkswagen Group, Nissan Manufacturing, Elcoteq, TPV Technology, and Foxconn. In the past 12 years we have furnished thousands of Russian industrial enterprises, since 2007 we also sell our products to European electronics and semiconductor industry companies from Belgium, Czech Republic, Finland, France, Germany, Hungary, Netherlands and others.

VIKING ESD and technical furniture manufacturing site is located near Saint-Petersburg and occupies the territory of over 6.000 square meters. In metal cutting area, painting zone and woodshops antistatic and technical furniture is produced, then processed in assembling and packing sections and stored in a spacious warehouse.

We constantly monitor manufacturing process and quality of our workbenches on all stages, which is acknowledged by ISO 9001:2008 certificate. For antistatic furniture, strict compliance with IEC 61340 is guaranteed.

## VIKING TECHNICAL AND ESD FURNITURE

Today VIKING brand offers a wide range of different workplaces, technical and ESD furniture and antistatic equipment. We designed and produce VIKING furniture as reliable, durable, ergonomic and easy to assemble products.

VIKING technical furniture provides ergonomic working area for any company and is distinguished by:

- Wide range of functional, convertible and interchangeable modules for each particular employee;
- Adjustment, layout and customization according to clients' specific needs;
- Possibility of modernization and refitting after the purchase;
- Strict compliance with the international antistatic standard IEC 61340.

VIKING technical furniture product range includes workbenches of different types, drawer units, equipment trolleys, carts and shelving, storage and wardrobe cabinets, ESD chairs and other ESD equipment and accessories. Most furniture units are offered in two versions - antistatic (ESD-protected) and technical ones.

## VKG TOOLS ESD EQUIPMENT

Besides a broad line of furniture, we offer a wide range of antistatic products and consumables to fully equip ESD-protected areas. Among them, one can find garments, storage and transportation means, monitoring and audit devices. These products are sold under VKG TOOLS brand.

In 2013 DIPAUL group has opened its branch office and a central distribution warehouse in Prague (Czech Republic) to provide a close support to its partners and distributors in the European region.

## TABLE OF CONTENT

VIKING technical furniture Configurator	4
Online 3D workspace Planner	5
VIKING workplaces series	7
- ALPHA series workbenches	8
- ALLIANCE series workbenches	10
- ALLIANCE automatic workbenches	12
- CLASSIC series workbenches	14
- COMFORT series workbenches	16
- CONSTANT series workbenches	18
- OSTROV series workbenches	20
- VERSTAK series heavy duty workbenches	22
- Universal workbenches	24
Specialized workbenches	24
Customized layouts	25
Workplaces additional equipment, grounding equipment	28
Test and measurement equipment	33
Drawer units	34
- Enlarged cabinets and drawer units	36
- Additional equipment for drawers	36
- ALPHA cabinet	37
Movable tables and carts	38
Movable trolleys	40
Cabinets and wardrobes	42
Sliding shutters cabinets	44
Shelving	45
ESD chairs	46
ESD garments	48
Our customers	50

# VIKING TECHNICAL FURNITURE CONFIGURATOR



Most VIKING technical and ESD workbenches consist of functional and interchangeable modules to provide maximum flexibility and help customer create customized workplaces, which satisfy any specific working process requirements. It may become an uneasy process to assemble certain set and make a choice of elements guided solely by modules description and codes. With our online service – VIKING technical and ESD furniture Configurator ([www.viking-esd.com/configurator](http://www.viking-esd.com/configurator)), which interactively guides user along the process of workbench assembling, it's much easier to make the right choice.

VIKING technical and ESD furniture Configurator helps to choose necessary basic modules and additional equipment of a future workplace online. It simplifies the process of assembling a workbench set, saves time and helps to avoid possible mistakes in different modules compatibility.

After choosing required options and elements one can place an order for chosen set to any VIKING official distributor online, print the individual set or use the picture and the list of modules for future orders.

VIKING technical furniture Configurator is also useful for workplaces amendment. Any time after the purchase customer can add or change workplaces' modules so that differently equipped workplaces are able to meet new requirements of the manufacturing process or any changed conditions.

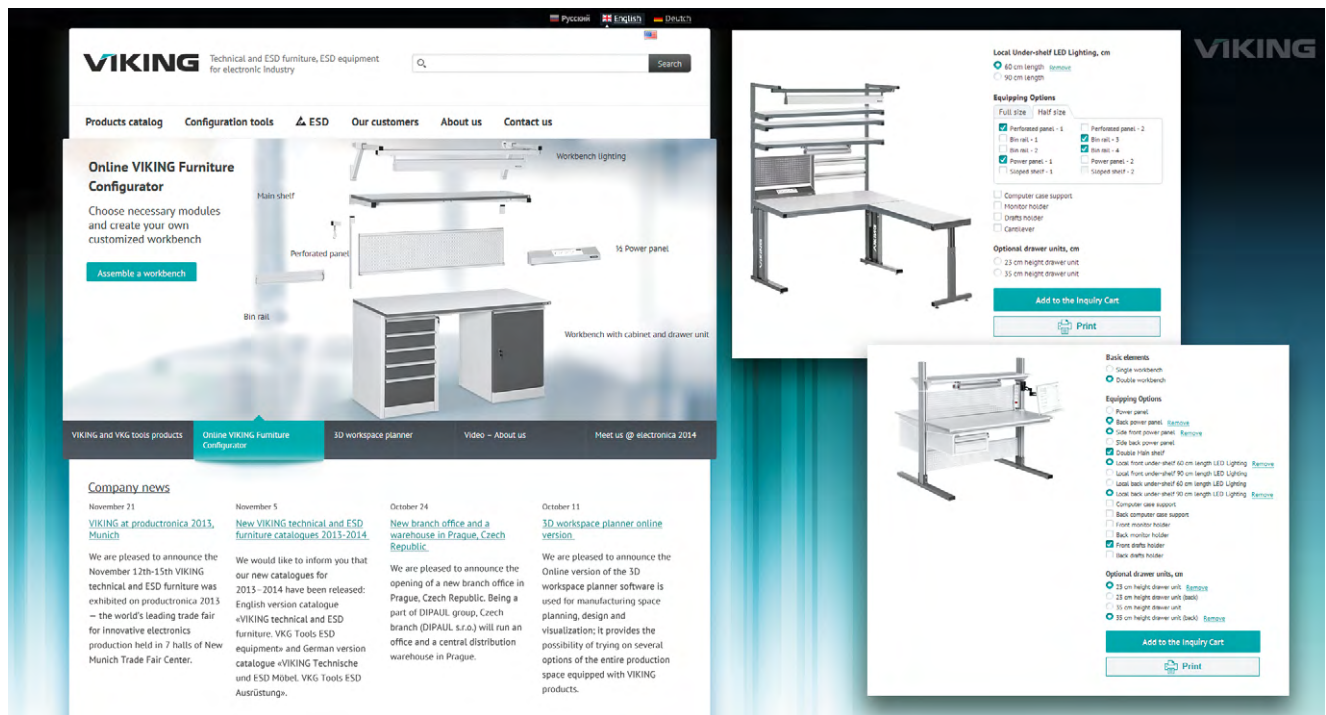
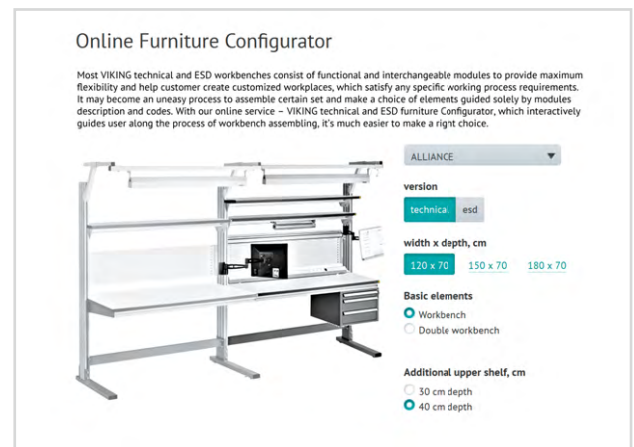

## ONLINE 3D WORKSPACE PLANNER

The 3D online workspace planner software is used for manufacturing space retrofitting planning, design and visualization; it provides the possibility of trying on several options of the entire production area equipment with VIKING furniture and additional elements.

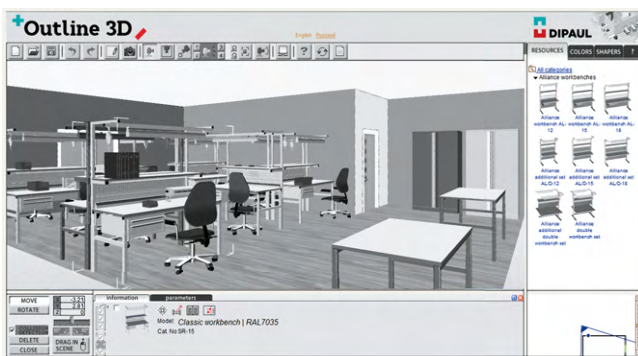
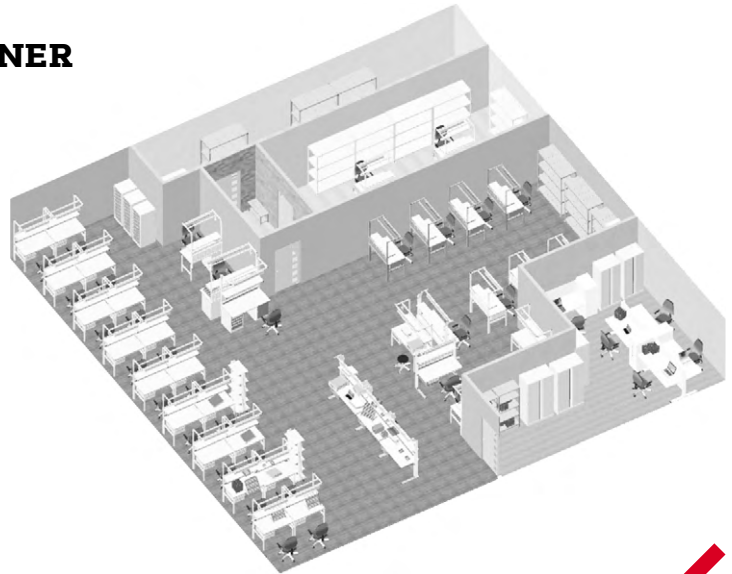

While being on the stage of planning new manufacturing facilities, workspace refurbishing or reequipping it's very useful to have the ability to compare different types of furniture and equipment layouts. Using the exact halls dimensions 3D Planner user can build up a 3D plan of the hall, estimate the quantity of necessary technical furniture and their disposition, arrange workplaces, passageways and utility premises. Our online 3D workspace Planner allows to specify windows, doors, columns sizes and positions, and also to choose colors and shapes of additional elements.

Online software is free and can be used by any [www.viking-esd.com](http://www.viking-esd.com) visitor; one just needs to install a plug-in to their computer.

As a result of working in 3D workspace planner, a user gets visual plans of re-equipped halls in isometric, top and 3d front view and detailed list of chosen furniture and equipment. All hall plans can be saved in standard .jpg format images which are easy to be sent, viewed or printed. One can also save 3D designs in specific .o3d format and continue the work later.



## VIKING WORKPLACES SERIES

**VIKING** products are available in technical (general) and ESD versions, the latter are marked with ESD label.

**Steel** frames are powder-coated in dark grey (RAL 7012) or light grey (RAL 7035) color, tabletops are resistant to abrasion. VIKING workbenches are modular, which allow customers to order only necessary parts and get workplaces for any specific use.

**Sets** of furniture can be supplemented by additional equipment at any time after the purchase. Assembly and installation is quick and simple, clear assembly instructions are provided with each module. Worktops and shelves are designed to endure big loads. Rigid and robust construction of VIKING workbenches provides reliable usage and thought-out ergonomics - for comfortable work. VIKING ESD-protected products are compliant with IEC 61340 standard, have corresponding certificates and test reports.

**VIKING** workbenches product range includes a wide line of functional, convertible and interchangeable modules for each particular enterprise. To facilitate configuration and simplify different elements choosing, our customers are welcome to use CONFIGURATOR (<http://www.viking-esd.com/configurator>), our online service which helps to interactively select all necessary workbench parts. After choosing required options and elements one can print the individual set and use the picture and the list of modules for future orders.

We divide our workbenches and supplementary elements in several series; each has its own peculiarities:

- **ALLIANCE** workbenches are distinguished by elegant design, advanced ergonomics and convenient system of height adjustment. They can be placed in an inseparable line where each two tabletops are held by lateral frames and share those in the middle. Mirror-like situated double workbenches also available.
- **ALPHA** series workbenches are designed as an extension of Alliance series product line. Alpha series workbenches allow effective use of space, offer practical structures and a compact size.
- **CLASSIC** workplaces are simple, functional and inexpensive. They can be placed in a line with no gaps for conveyor work.
- **COMFORT** workbenches that look more appealing and offer advanced ergonomics for comfortable work.
- **CONSTANT** workbenches with fixed worktop height are equipped with functional supports and can withstand an increased load.
- **OSTROV** workbenches that are mirror-like situated, are designed for the most effective use of workspace.
- **VERSTAK** heavy duty workbenches are available only in non-antistatic version, but their rigidity and different tabletop and support types will be useful for manufacturing process.
- **UNIVERSAL** workbenches, the simplest and cheapest ones, they do not allow any above tabletop extension.
- **SPECIALIZED** workbenches were made to satisfy specific working process requirements.

In addition, we can always manufacture customized products and are confident of our ability to satisfy and meet our customer's individual requirements.



**ALPHA** SERIES WORKBENCHES

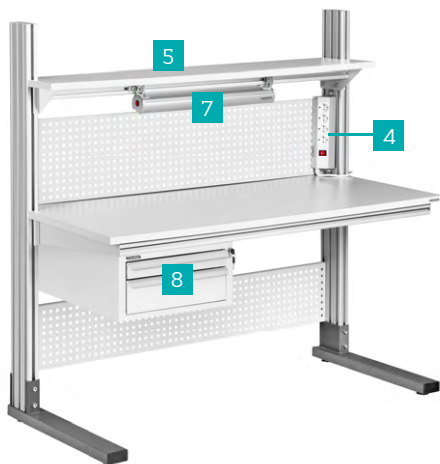

1



2



Alpha series workbenches are designed as a space-saving extension of Alliance series product line. Stylish and ergonomic workbenches can perfectly equip unspecified technical premises and educational facilities. Alpha series workbenches are distinguished by practical modular construction and compact size; they allow effective use of hall [space](#).

We offer 2 models of Alpha series workbenches:

**1** single workbench **2** mirror-located double workbench.

### 1 ALF Single workbench

This comfortable workbench is perfect for small premises which require space-saving equipment. It is recommended for office and engineering personnel, also used for training and educational premises.

Workbench is supplied in a set with 2 perforated panels.

- Adjustable tabletop height
- Workplace height: 1500 mm
- Load capacity: 200 kg

### 2 ALF-O Double workbench

Double workbench with 2 mirror located tabletops, helps to save space and reduce costs. Workbench is supplied in a set with 2 double perforated panels and 2 tabletops.

- Adjustable tabletop height
- Workplace height: 1500 mm
- Each tabletop load capacity: 200 kg

### 3 ALF-EPA Power panel

Basic configuration consists of 4 sockets in an aluminium case with protective contact and 3 m cable. Power panel can be mounted either on or below tabletop, fastening set is similar. Can be equipped with additional sockets, fuses, phone jacks and earth leakage circuit breakers.

Nominal load capacity: 10 A

### 4 ALF-EPA/B Side power panel

4 sockets with protective contact and 3 m cable in a small aluminium case. Side power panel can be mounted either on any part of lateral aluminium frame. No extension possible.

- Nominal load capacity: 10 A

### 5 ALF-PO Main shelf

Main shelf for Alpha series single workbenches.

- 30 cm depth
- Load capacity: 70 kg
- Height adjustment: 1200 – 1500 mm.

### 6 ALF-O-PO Double main shelf

Main shelf for Alpha series double workbenches.

- 30 cm depth from each side
- Load capacity: 150 kg
- Height adjustment: 1200 – 1500 mm.

CODE ↓	DIMENSIONS
ALF-12-7	1200x700 mm
ALF-15-7	1500x700 mm
ALF-18-7	1800x700 mm
ALF-O-12-7	2 *(1200x700) mm
ALF-O-15-7	2* (1500x700) mm
ALF-O-18-7	2* (1800x700) mm

### 7 Under-shelf local lighting DL/N

Additional local LED lighting can be mounted to any workbench series Main shelf and Perforated panel

- 2 versions: 60 cm length and 90 cm length
- Angle adjustment 120°

### 8 TP-O1/P, TP-O2/P Optional drawer units

Storage solution for tools and components, no place on floor required. Each drawer is equipped with drawer's closer mechanism to provide sliding evenness.

- TP-O1/P: 490x580x354 mm
- TP-O2/P: 490x580x233 mm

### 9 ALF-TMB-O2 cabinet

Spacious metal cabinet for documents, folders and personal belongings; can be attached to a workbench by bolts.

**Equipped with:**

- 2 standard drawers
- 2 sliding shelves with perforated side wall, which can be placed on right or left side depending on further usage.

Dimensions: 445x700x1285 mm.

Distributed load capacity for each shelf: 30 kg.

Additional equipment for ALF-TMB cabinet:  
shelves dividers

### D-7/ALF Drawer's horizontal dividers

7 horizontal 335 mm length dividers help to organize cells for different small items.

### D-4/ALF Sliding shelf's vertical dividers

4 vertical 240 x 290 mm dividers help to organize slots for folders and documents.

**See more on p.37**

When ordering, please, mention whether ESD or technical version, and whether dark grey RAL 7012 or light grey RAL 7035 color required.



**ALLIANCE** SERIES WORKBENCHES

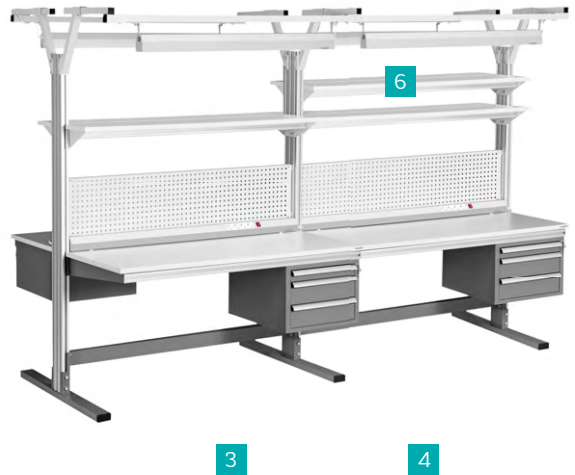
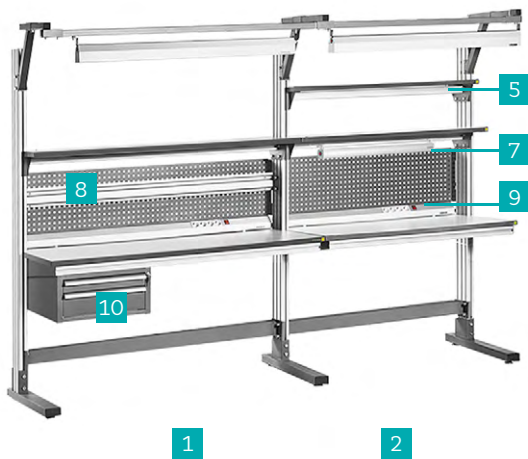

**Alliance** workbenches are distinguished by elegant design, advanced ergonomics and convenient system of height adjustment. Due to possibility of broadened worktop, main shelf and lighting height adjustments, these workbenches are very comfortable to work at, even in the upright position. One can quickly make any adjustments by his own and fix working surfaces by key wrenches.

We also offer motorized worktop adjustment embodied in Alliance Automatic series workbenches AL-A. See more on p.13.

**Several** Alliance workbenches can be placed in an inseparable line where two tabletops are held by side lateral frames and share those in the middle. Mirror-like double Alliance workbenches can also be put same way and build up total working area.

Possible tabletop height adjustment: 600 - 1300 mm.

Possible lighting height adjustment: 1200 - 2000 mm.

CODE ↓	DIMENSIONS
AL-12-7 / AL/D-12-7	1200x700 mm
AL-15-7 / AL/D-15-7	1500x700 mm
AL-18-7 / AL/D-18-7	1800x700 mm
AL-O-12-7 / AL-O/D-12-7	2*(1200x700) mm
AL-O-15-7 / AL-O/D-15-7	2*(1500x700) mm
AL-O-18-7 / AL-O/D-18-7	2*(1800x700) mm

**Standard** Alliance workbenches are powder-coated in dark grey color (RAL 7012) for lower steel modules and light grey color (RAL 7035) for tabletops and shelves.

**Alliance** series workbenches are supplied in a set with lower cleat, perforated panel, main shelf and lighting.

#### 1 AL Alliance set

Single workbench with two lateral aluminium frames. The workbench is supplied in a set with lower slat, perforated panel, main shelf and lighting.

- Load capacity: 200 kg

#### 2 AL/D Alliance additional set

Additional set with one lateral aluminium frame is meant to be attached to main Alliance workbench from either side, which provides inseparable working surface line.

The set includes: workbench with one lateral frame, lower slat, perforated panel, main shelf and lighting.

- Load capacity: 200 kg

#### 3 AL-O Alliance double set

Mirror-like double workbench with two lateral aluminium frames. The workbench is supplied in a set with double lower slat, double-sided perforated panel, double main shelf and two lighting units.

- Each tabletop load capacity: 200 kg

#### 4 AL-O/D Alliance additional set

Mirror-like double workbench with one lateral aluminium frame to be attached to main Alliance double workbench. The workbench is supplied in a set with double lower slat, double-sided perforated panel, double main shelf and two lighting units.

- Each tabletop load capacity: 200 kg

#### 5 AL-PO/1 Additional shelf

Additional shelf for Alliance series workbenches.

- 2 versions: 30 cm depth and 40 cm depth
- Load capacity: 100 kg
- Height adjustment above tabletop: 1000 - 1850 mm.

#### 6 AL-O-PO/1 Additional double shelf

Additional double shelf for double Alliance series workbenches.

- 2 versions: 30 cm depth and 40 cm depth from each side
- Load capacity: 100 kg
- Height adjustment above tabletop: 1000 - 1850 mm.

#### 7 Under-shelf local lighting DL/N

Additional local LED lighting can be mounted to any workbench series Main shelf and Perforated panel

- 2 versions: 60 cm length and 90 cm length
- Angle adjustment 120°

#### 8 AL-RK Bin rail

Aluminum rail for bin storage placed along workbench length.

- Load capacity: 10 kg

#### 9 AL-EP Power panel

Basic configuration consists of 4 sockets placed in aluminium case with protective contact and 3 m cable. Panel can be equipped with additional sockets, earth leakage circuit breaker, automatic fuse and a phone jack.

- Nominal load capacity: 10 A
- Grounding cord cross-section: 0.75 mm

#### 10 TP-01/P, TP-02/P Optional drawer units

Storage solution for tools and components, no place on floor required. Dimensions:

- TP-01/P: 490 x 354 x 580 mm
- TP-02/P: 490 x 233 x 580 mm

When ordering, please, mention whether ESD or technical version required.



**ALLIANCE** AUTOMATIC WORKBENCHES





**CLASSIC** SERIES WORKBENCHES

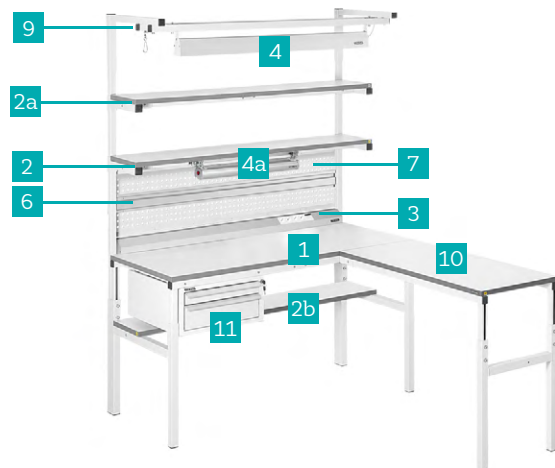
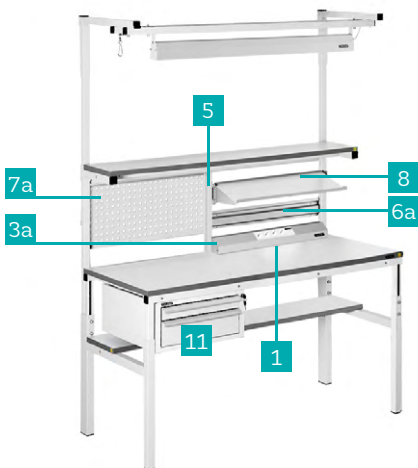

## 1 SR Workbench

These workbenches can be placed in a line to make a common working area with no gaps. Universal design allows fitting out the workplace with additional equipment and drawer units.

Height adjustment: 650 - 950 mm

Load capacity: 300 kg

Temperature resistance: 300 °C

## 2 PO Main shelf

Rear racks included.

- 2 versions: 30 cm depth and 40 cm depth
- Height adjustment: 1000 - 1800 mm
- Load capacity: 50 kg

### 2a PO/1 Additional shelf

Requires PO Main shelf to be installed.

- 2 versions: 30 cm depth and 40 cm depth
- Height adjustment: 1100 - 1800 mm
- Load capacity: 50 kg

### 2b PO/2 Underneath shelf

Not compatible with TP-01/P Optional drawer unit.

- 2 versions: 30 cm depth and 40 cm depth
- Load capacity: 100 kg

## 3 EP Power panel

### 3a ½EP Power panel

Basic configuration consists of 4 sockets placed in aluminium case with protective contact and 3 m cable. Panel can be equipped with additional sockets, earth leakage circuit breaker, automatic fuse and a phone jack.

- Nominal load capacity: 10 A
- Grounding cord cross-section: 0.75 mm

## 4 DL/A Workbench lighting

DL/A Workbench lighting is placed in an aluminum case with 2 energy-efficient luminescent 54 W lamps, light direction regulation and shadowless reflector provided. Quick switching on without shimmering, no strobing freeze.

- Length: 1200 mm
- Height adjustable
- Illuminance at 1000 mm distance:
  - 1200 lux central
  - 800 lux peripheral

### 4a Under-shelf local lighting DL/N

Additional local LED lighting can be mounted to any workbench series Main shelf and Perforated panel

- 2 versions: 60 cm length and 90 cm length
- Angle adjustment 120°

## CODE ↓

## DIMENSIONS

SR-12-7	1200x700 mm
SR-15-7	1500x700 mm
SR-18-7	1800x700 mm
SR-12-9	1200x900 mm
SR-15-9	1500x900 mm
SR-18-9	1800x900 mm

## 5 Middle upright for all items

Required to hold any ½ item. 3 sizes to match standard workbench width.

## 6 RK Bin rail

### 6a ½RK Bin rail

Aluminum rail for bin storage placed along workbench length.

- Load capacity: 10 kg

## 7 PFP Perforated panel

### 7a ½PFP Perforated panel

Panel can be equipped with different holders for additional equipment and tools storage.

## 8 PN Sloped shelf

Half-sized shelf. Angle adjustment provides comfort monitoring of working equipment.

- Load capacity: 50 kg

## 9 IP Cantilever

It was designed for easy-to-reach attaching of drawings, lighting and instruments. IP Cantilever can be additionally equipped by retracting KL-1200 mechanism.

## 10 US-1 Corner workbench

- Dimensions: 1200x500 mm

## 11 TP-01/P, TP-02/P Optional drawer units

Storage solution for tools and components, no place on floor required. Dimensions:

- TP-01/P: 490x354x580 mm
- TP-02/P: 490x233x580 mm

When ordering, please, mention whether ESD or technical version, and whether dark grey RAL 7012 or light grey RAL 7035 color required.

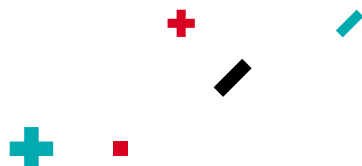

COMFORT SERIES WORKBENCHES

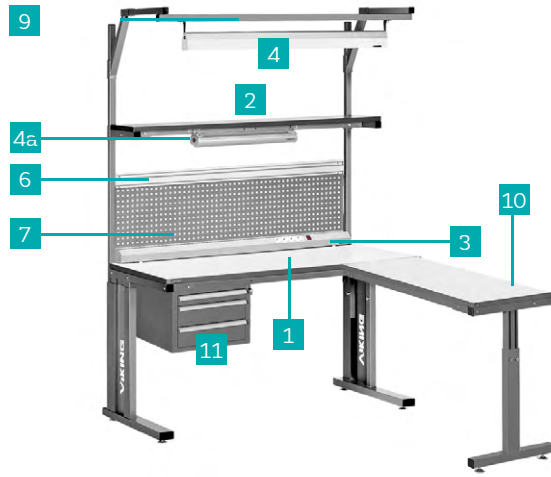
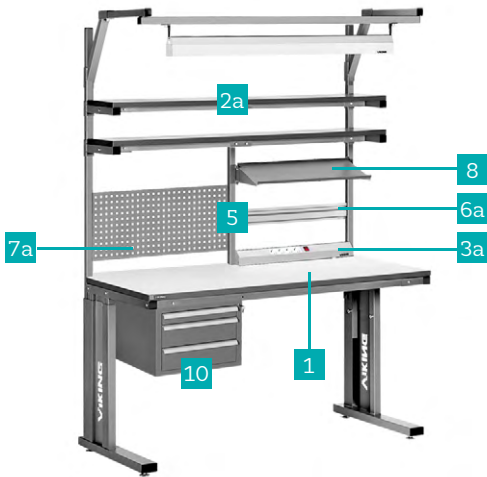



## 1 SR COMFORT Workbench

These workbenches offer advanced ergonomic characteristics.

- Height adjustment: 800 - 950 mm
- Load capacity: 200 kg
- Heat resistance: 300 °C

## 2 PO Main shelf

Rear racks included.

- 2 versions: 30 cm depth and 40 cm depth
- Height adjustment: 1000 - 1850 mm
- Load capacity: 50 kg

### 2a PO/1 Additional shelf

Requires PO Main shelf to be installed.

- 2 versions: 30 cm depth and 40 cm depth
- Height adjustment: 1100 - 1850 mm
- Load capacity: 50 kg

## 3 EP Power panel

### 3a ½ EP Power panel

Basic configuration consists of 4 sockets placed in aluminium case with protective contact and 3 m cable. Panel can be equipped with additional sockets, earth leakage circuit breaker, automatic fuse and a phone jack.

- Nominal load capacity: 10 A
- Grounding cord cross-section: 0.75 mm

## 4 DL/A COMFORT Workbench lighting

DL/A Comfort Workbench lighting is placed in an aluminum case with 2 energy-efficient luminescent 54 W lamps, light direction regulation and shadowless reflector provided. Quick switching on without shimmering, no strobe effect.

- Length: 1200 mm
- Height adjustable
- Illuminance at 1000 mm distance:
  - 1200 lux central
  - 800 lux peripheral

### 4a Under-shelf local lighting DL/N

Additional local LED lighting can be mounted to any workbench series Main shelf and Perforated panel

- 2 versions: 60 cm length and 90 cm length
- Angle adjustment 120°

## CODE ↓

## DIMENSIONS

SR-12-7 Comfort	1200x700 mm
SR-15-7 Comfort	1500x700 mm
SR-18-7 Comfort	1800x700 mm

## 5 Middle upright for all items

Required to hold any ½ item. 3 sizes to match standard workbench width.

## 6 RK Bin rail

### 6a ½ RK Bin rail

Aluminum rail for bin storage placed along workbench length.

- Load capacity: 10 kg

## 7 PFP Perforated pane

### 7a ½ PFP Perforated panel

Panel can be equipped by different holders for additional equipment and tools storage.

## 8 PN Sloped shelf

Half-sized shelf. Angle adjustment provides comfort monitoring of working equipment.

- Load capacity: 50 kg

## 9 IP Cantilever

It was designed for easy-to-reach attaching of drawings, lighting and instruments. IP Cantilever can be additionally equipped by retracing KL-1200 mechanism.

## 10 US-1 COMFORT Corner workbench

Dimensions: 1200x500 mm.

## 11 TP-01/P, TP-02/P Optional drawer units

Storage solution for tools and components, no place on floor required. Dimensions:

- TP-01/P: 490x354x580 mm
- TP-02/P: 490x233x580 mm

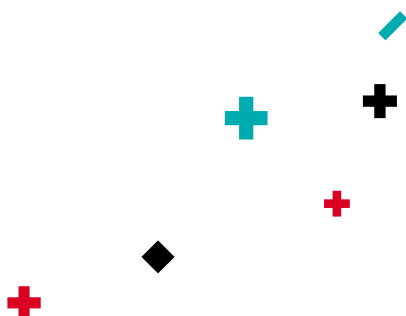

When ordering, please, mention whether ESD or technical version, and whether dark grey RAL 7012 or light grey RAL 7035 color required.



**CONSTANT** SERIES WORKBENCHES

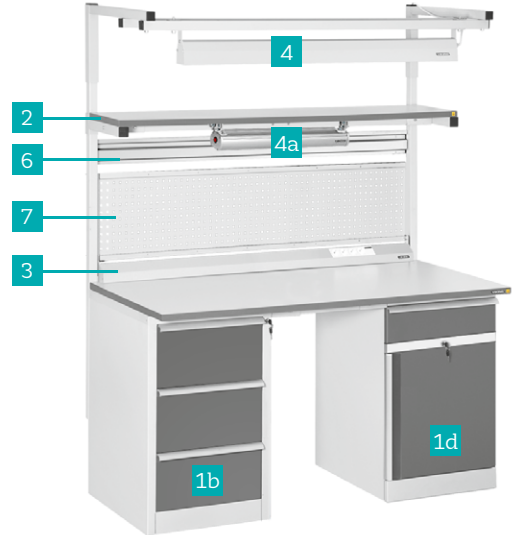
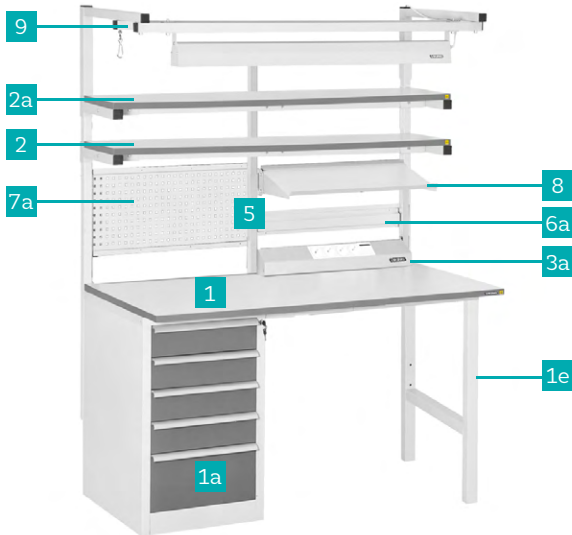

## 1 SR CONSTANT Workbenches

These workbenches cannot be height-adjusted.

- Tabletop height: 825 mm
- Load capacity: 300 kg

**As a support, Constant workbenches can have:**

**1a** Cabinet unit with 5 drawers on telescopic runners and a lock (+DR-05)

**1b** Cabinet unit with 3 bigger drawers on telescopic runners and a lock (+DR-03)

**1c** Cabinet with 2 shelves and a lock (+ TMB-01)

**1d** Cabinet with 1 drawer and 2 shelves in a locked section (+ TMB-02)

**1e** Legs

Supports are manufactured in any combination, except for 1200 mm width workbenches that should have legs as one support.

## 2 PO Main shelf

Rear racks included.

- 2 versions: 30 cm depth and 40 cm depth
- Height adjustment: 1000 - 1850 mm
- Load capacity: 50 kg

### 2a PO/1 Additional shelf

Requires PO Main shelf to be installed.

- 2 versions: 30 cm depth and 40 cm depth
- Height adjustment: 1100 - 1800 mm
- Load capacity: 50 kg

## 3 EP Power panel

### 3a ½ EP Power panel

Basic configuration consists of 4 sockets placed in an aluminium case with protective contact and 3 m cable. Panel can be equipped with additional sockets, earth leakage circuit breaker, automatic fuse and a phone jack.

- Nominal load capacity: 10 A
- Grounding cord cross-section: 0.75 mm

## 4 DL/A Workbench lighting

DL/A Workbench lighting is placed in an aluminum case with 2 energy-efficient luminescent 54 W lamps, light direction regulation and shadowless reflector provided. Quick switching on without shimmering, no strobe effect.

- Length: 1200 mm
- Height adjustable
- Illuminance at 1000 mm distance: 1200 lux central and 800 lux peripheral

### 4a Under-shelf local lighting DL/N

Additional local LED lighting can be mounted to any workbench series Main shelf and Perforated panel

- 2 versions: 60 cm length and 90 cm length
- Angle adjustment 120°

## CODE ↓

## DIMENSIONS

SR-12-7+DR-05 / SR-12-7+DR-03 / SR-12-7+TMB-01 / SR-12-7+TMB-02 /	1200 x 700 mm
SR-15-7+DR-05 / SR-15-7+DR-03 / SR-15-7+TMB-01 / SR-15-7+TMB-02 / SR-15-7+DR-05+DR-05 / SR-15-7+DR-03+DR-05 / SR-15-7+DR-03+DR-03 / SR-15-7+TMB-01+TMB-01 / SR-15-7+TMB-02+TMB-02 / SR-15-7+TMB-01+TMB-02 / SR-15-7+DR-05+TMB-01 / SR-15-7+DR-03+TMB-01 / SR-15-7+DR-05+TMB-02 / SR-15-7+DR-03+TMB-02 /	1500 x 700 mm
SR-18-7+DR-05 / SR-18-7+DR-03 / SR-18-7+TMB-01 / SR-18-7+TMB-02 / SR-18-7+DR-05+DR-05 / SR-18-7+DR-03+DR-05 / SR-18-7+DR-03+DR-03 / SR-18-7+TMB-01+TMB-01 / SR-18-7+TMB-02+TMB-02 / SR-18-7+TMB-01+TMB-02 / SR-18-7+DR-05+TMB-01 / SR-18-7+DR-03+TMB-01 / SR-18-7+DR-05+TMB-02 / SR-18-7+DR-03+TMB-02 /	1800 x 700 mm

## 5 Middle upright for all items

Required to hold any ½ item. 3 sizes to match standard workbench width.

### 6 RK Bin rail

### 6a ½ RK Bin rail

Aluminum rail for bin storage placed along workbench length.

- Load capacity: 10 kg

### 7 PFP Perforated panel

### 7a ½ PFP Perforated panel

The panel can be equipped by different holders for additional equipment and tools storage.

## 8 PN Sloped shelf

Half-sized shelf. Angle adjustment provides comfort monitoring of working equipment.

- Load capacity: 50 kg

## 9 IP Cantilever

Cantilever is designed for easy-to-reach attaching of drawings, lighting and instruments. Cantilever can be additionally equipped by retracting KL-1200 mechanism.

When ordering, please, mention whether ESD or technical version, and whether dark grey RAL 7012 or light grey RAL 7035 color required.



**OSTROV** SERIES WORKBENCHES

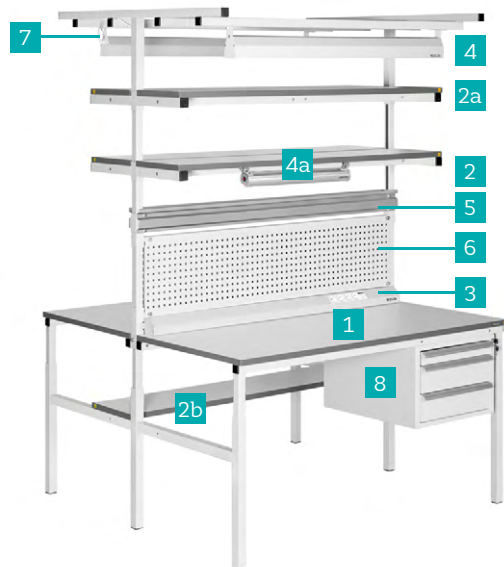

### 1 SO Workbench

Two mirror-like situated workbenches allow effective use of space. Basic configuration includes 300 mm shelves for each workplace

- Height adjustment: 655 - 950 mm
- Load capacity: 300 kg
- Temperature resistance: 300 °C

### 2a PO-O Additional shelf

Height adjustment: 1100 - 1800 mm

- 2 versions: 30 cm depth and 40 cm depth from each side
- Load capacity: 50 kg

### 2b PO/2 Underneath shelf

Not compatible with optional TP-01/P drawer.

2 versions: 30 cm depth and 40 cm depth

- Load capacity: 100 kg

### 3 EP-O Power panels

Basic configuration consists of 2 aluminium cases each with 4 sockets with protective contacts and 3 m cables. Panels can be equipped with additional sockets, earth leakage circuit breakers, automatic fuses and phone jacks.

- Nominal load capacity: 10 A
- Grounding cord cross-section: 0.75 mm

### 4 DL-O/A Workbench lighting

DL-O/A Workbench lightings are placed in aluminum cases, each with 2 energy-efficient luminescent 54 W lamps, light direction regulation and shadowless reflector. Quick switching on without shimmering, no strobing freeze.

- Length: 1200 mm
- Height adjustable
- Illuminance at 1000 mm distance: 1200 lux central and 800 lux peripheral

### 4a Under-shelf local lighting DL/N

Additional local LED lighting can be mounted to any workbench series Main shelf and Perforated panel

- 2 versions: 60 cm length and 90 cm length
- Angle adjustment 120°

### CODE ↓

### DIMENSIONS

SO-12-7	2x(1200x700) mm
SO-15-7	2x(1500x700) mm
SO-18-7	2x(1800xx700) mm

### 5 Double bin rail

Double aluminum rail for storage placed along workbench length.

- Load capacity: 10 kg

### 6 Double perforated panel

The panel can be equipped by different holders for additional equipment and tools storage.

### 7 IP Cantilever

It was designed for easy-to-reach attaching of drawings, lighting and instruments. IP Cantilever can be additionally equipped by retracting KL-1200 mechanism.

### 8 TP-01/P, TP-02/P Optional drawer units

Storage solution for tools and components, no place on floor required.

Dimensions:

- TP-01/P: 490x354x580 mm
- TP-02/P: 490x233x580 mm

When ordering, please, mention whether ESD or technical version, and whether dark grey RAL 7012 or light grey RAL 7035 color required.



## VERSTAK SERIES HEAVY DUTY WORKBENCHES

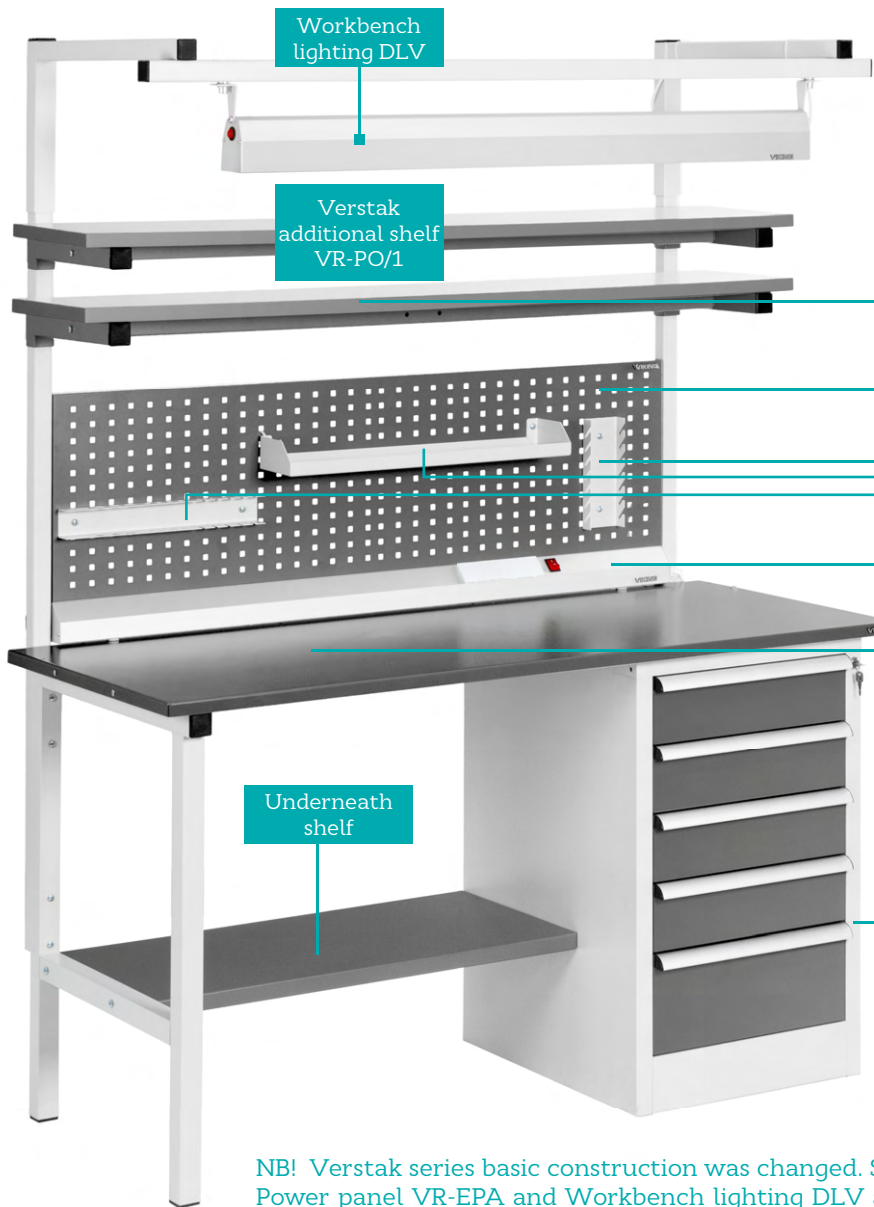

VERSTAK series offer module workbenches of heightened rigidity and durability with distributed load capacity of over 500 kg. These workbenches offered only in technical /non-antistatic version.

- Verstak main shelf VR-PO
- Perforated panel PRV
- Holders
- Power panel VR-EP
- Tabletop
- Drawer unit

Maximum functionality is achieved by a range of tabletops, supports and additional equipment. Standard width is 630 mm and height - 800 mm plus tabletop's thickness.

NB! Verstak series basic construction was changed. Since now Perforated panel PRV, Power panel VR-EPA and Workbench lighting DLV are mounted to Rear Racks that are supplied in a set with Main shelf or should be ordered separately if Main shelf isn't required. Perforated panel is supplied in a set with small rear racks thus can be ordered separately from other upper modules.

There are 4 types of tabletops

Type 1	21 mm thick plywood with light grey plastic edges.
Type 2	21 mm thick plywood covered by 2 mm dark grey metal sheet, the latter is bent over edges.
Type 3	21 mm thick plywood with light grey plastic edges covered by 6 mm dark grey metal sheet.
Type 4	6 mm thick dark grey metal sheet.



There are 5 standard types of worktop supports

- 1a Cabinet unit with 5 drawers on telescopic runners and a lock (+DR-05)
- 1b Cabinet unit with 3 bigger drawers on telescopic runners and a lock (+DR-03)
- 1c Cabinet with 2 shelves and a lock (+ TMB-01)
- 1d Cabinet with 1 drawer and 2 shelves in a locked section (+ TMB-02)
- 1e Legs



These supports can be combined, but 1200 mm width Verstack workbenches should have legs as one support.

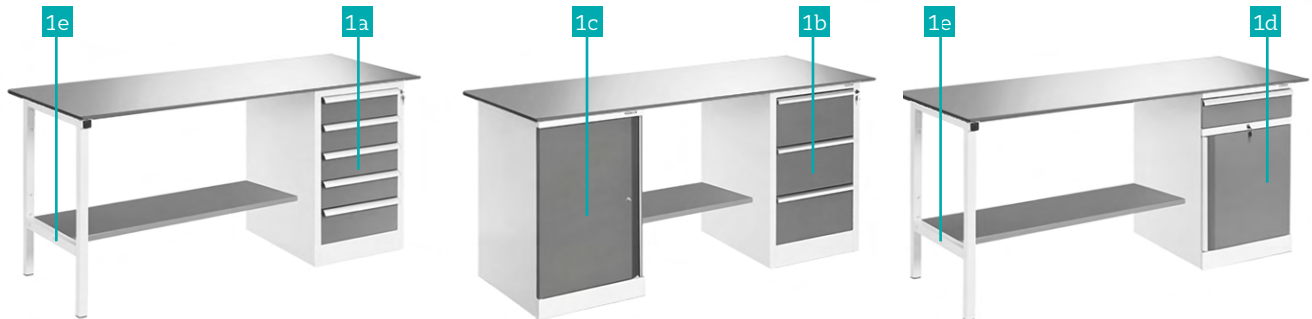

	VR: Verstack with a drawer unit (DR-03 or DR-05)	VR-12+DR-03/No.	VR-12+DR-05/No.	1200x630 mm
		VR-15+DR-03/No.	VR-15+DR-05/No.	1500x630 mm
		VR-18+DR-03/No.	VR-18+DR-05/No.	1800x630 mm
	VR: Verstack with a cabinet (TMB-01 or TMB-02)	VR-12+TMB-01/No.	VR-12+TMB-02/No.	1200x630 mm
		VR-15+TMB-01/No.	VR-15+TMB-02/No.	1500x630 mm
		VR-18+TMB-01/No.	VR-18+TMB-02/No.	1800x630 mm
	VR: Verstack with different combinations of cabinets (TMB-01, TMB-02) and drawer units (DR-03, DR-05)	VR-15+DR-05+DR-05/No.	VR-15+DR-03+DR-03/No.	1500x630 mm
		VR-15+DR-03+DR-05/No.	VR-15+TMB-01+TMB-01/No.	
		VR-15+TMB-01+TMB-02/No.	VR-15+TMB-02+TMB-02/No.	
		VR-15+DR-05+TMB-01/No.	VR-15+DR-05+TMB-02/No.	1800x630 mm
		VR-15+DR-03+TMB-02/No.	VR-15+DR-03+TMB-01/No.	
		VR-18+DR-05+DR-05/No.	VR-18+DR-03+DR-03/No.	
VR-18+DR-03+DR-05/No.	VR-18+TMB-01+TMB-01/No.	1800x630 mm		
VR-18+TMB-01+TMB-02/No.	VR-18+TMB-02+TMB-02/No.			
VR-18+DR-05+TMB-01/No.	VR-18+DR-05+TMB-02/No.			
VR-18+DR-03+TMB-02/No.	VR-18+DR-03+TMB-01/No.			

**Note:** No. in the workbench code corresponds to tabletop type (1, 2, 3 or 4).

PRV: Perforated panel for Verstack workbench (small shelf and 2 holders included)	PRV-12	for 1200 mm width workbenches
	PRV-15	for 1500 mm width workbenches
	PRV-18	for 1800 mm width workbenches
DLV: Workbench lighting. Requires Main shelf or Rear Racks to be installed	DLV-12	for 1200 mm width workbenches
	DLV-15	for 1500 mm width workbenches
	DLV-18	for 1800 mm width workbenches
VR-PO: Verstack main shelf	VR-PO-12	1200x300 mm
	VR-PO-15	1500x300 mm
	VR-PO-18	1800x300 mm
VR-PO/1: Verstack additional shelf	VR-PO/1-12	1200x300 mm
	VR-PO/1-15	1500x300 mm
	VR-PO/1-18	1800x300 mm
VR-EP: Verstack power panel	VR-EP-12	for 1200 mm width workbenches
	VR-EP-15	for 1500 mm width workbenches
	VR-EP-18	for 1800 mm width workbenches
DL/N: Under-shelf local lighting	DL/N-6	600 mm
	DL/N-9	900 mm

## UNIVERSAL WORKBENCHES

### SU Universal workbenches



The simplest and one of the cheapest workbench in our product range. UNIVERSAL workbenches do not allow any upper extension, but can be placed in a line with no gaps. 700 mm and 900 mm depth SU workbenches can be equipped with TP-01/P and TP-02/P Optional drawer units

CODE ↓	DIMENSIONS
SU-12-5	1200 x 500 mm
SU-12-7	1200 x 700 mm
SU-12-9	1200 x 900 mm
SU-15-5	1500 x 500 mm
SU-15-7	1500 x 700 mm
SU-15-9	1500 x 900 mm
SU-18-5	1800 x 500 mm
SU-18-7	1800 x 700 mm
SU-18-9	1800 x 900 mm

## SPECIALIZED WORKBENCHES

### KS Movable computer equipment workbench



**Space-saving** movable workbench for computer and measurement equipment storage and transportation.

Movable workbench for computer and measurement equipment is equipped with four 50 mm casters, 2 of which are with **brakes**.

**Standard** tabletop size 900x700 mm, tabletop height adjustment: 650 - 1000 mm.

Movable workbench for computer and measurement equipment has two shelves: 900x300 mm upper shelf and 900x400 mm lower shelf, both with 70 kg load capacity and a keyboard **support**.

### USS-SU Corner connecting workbench

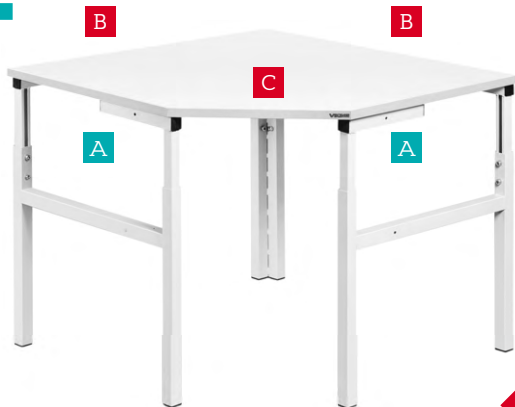

**Corner** connecting workbench is used to build up inseparable working area being a connector for two standard Classic, Comfort or Constant workbenches put at right angle. Increased depth of tabletop and load capacity of 200 kg allows storing and using heavy or bulky **equipment**.

**Corner** connecting workbench is produced in 2 sizes to match 700 mm depth workbenches and 900 mm depth workbenches. Perforated panel, main and additional shelves, lighting units and power panels can be mounted to corner connecting workbench on **request**.

When ordering, please, mention whether ESD or technical version, and whether dark grey RAL 7012 or light grey RAL 7035 color required.

CODE ↓	DIMENSIONS
USS-SU-7	<b>A</b> x <b>B</b> x <b>C</b> 700 x 1050 x 500 mm
USS-SU-9	<b>A</b> x <b>B</b> x <b>C</b> 900 x 1250 x 500 mm



## CUSTOMIZED LAYOUTS

We are pleased to offer customized layouts based on our clients' individual requirements and projects. One can change size, shapes, add necessary elements to any particular module.  
Each customized unit that was produced before can be offered again.

SR-ZHG Wire harness workbench



SHL-1 ESD cells wardrobe



EM-SR-14 Workbench for electrical installation operations



SR-P Customized shape workbench with additional multilevel shelves



ALF-N ALPHA series workbench with 3 aluminium supports and customized shape worktop



TTL-N Laboratory equipment transportation cart



TTU-N Transportation cart for heavy loads



## WORKPLACES ADDITIONAL EQUIPMENT, GROUNDING EQUIPMENT

PO-IP-12/15/18 Tabletop secondary structure



**Tabletop** secondary structure is equipped with additional power panel, the possibility of extension is provided: basic version includes four sockets and a switch, 2 sockets can be added for 1200 mm length item, 8 sockets can be added for 1500 mm length item and 13 sockets can be added for 1800 mm length item.

Power panel can also be equipped with additional sockets.

- Load capacity: 120 kg
- Dimensions: 1200/1500/1800x400x65 mm



KL-1200 Retracing mechanism



**Designed** to suspend instruments and make them easy-to-reach. Cable tension depends on the weight of the instrument which should be in a 0.6 - 1.5 kg range.

EP Power Panel accessories

- single socket with grounding
- double socket with grounding
- 10 A automatic fuse
- 16 A automatic fuse
- circuit breaker (F362-16/2/0.01-A)
- automatic circuit breaker with power line disturbances suppression.

PPN-02 Footrest

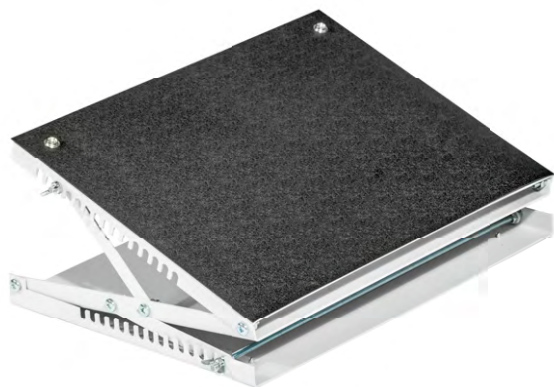

**Footrest** helps to provide workers with an ergonomically correct sitting position. PPN-02 footrest is equipped with height and angle adjustment mechanism. Dimensions: 400x300 mm.



PPCH-01 / PPCH-01/A Drafts holders

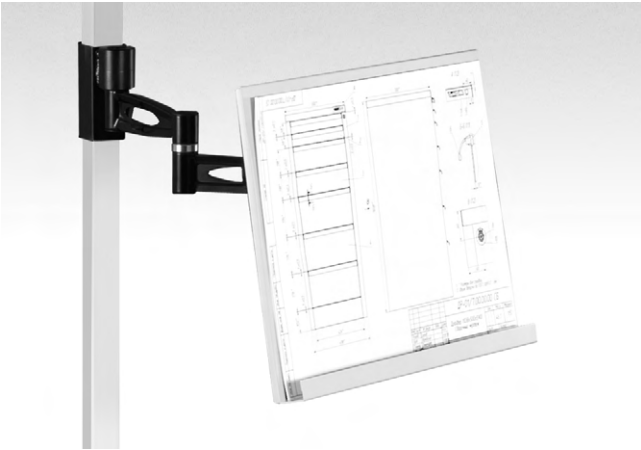

**Adjusting** drafts holder. Supplied in a set with 2 VIKING magnets. Requires PO Main shelf or Rear racks for SR series workbenches. Mounted to aluminium racks when used with Alpha or Alliance series workbenches.

- Load capacity: 15 kg

PPM-03 / PPM-03/A Monitor supports



**Adjusting** support helps to save space on the tabletop. Requires PO Main shelf or Rear racks for SR series workbenches. Mounted to aluminium racks when used with Alpha or Alliance series workbenches.

- Load capacity: 15 kg

PPS-01 Movable computer case support



220x150x480 mm support helps to move the computer case around the area.

PPS-03 Suspended computer case support

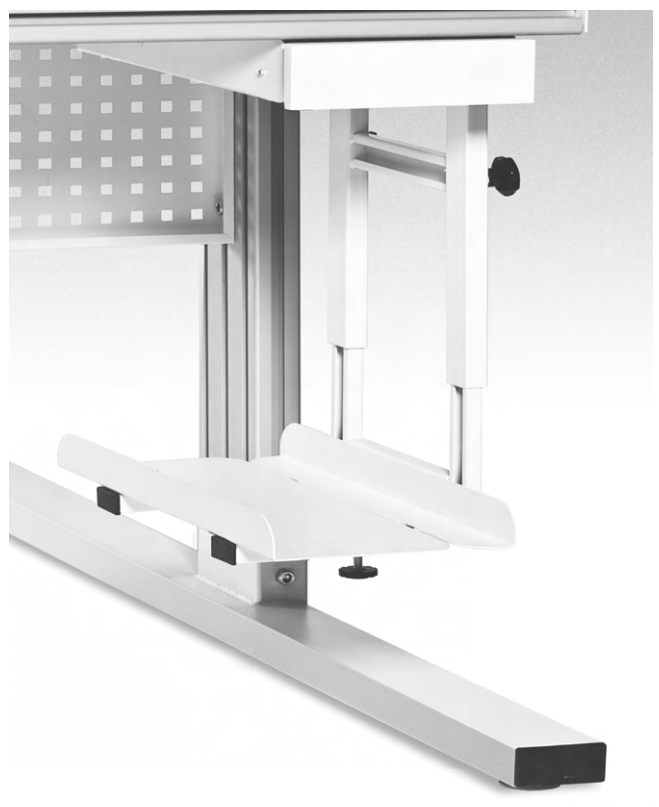

Dimensions (W×H×D): 265x460x460 mm. Suitable for any VIKING workbench.

### ARK Bin rail



Aluminium rail can be installed wherever on the wall to hold attached storage bins.



### Under-shelf local LED lighting DL/N

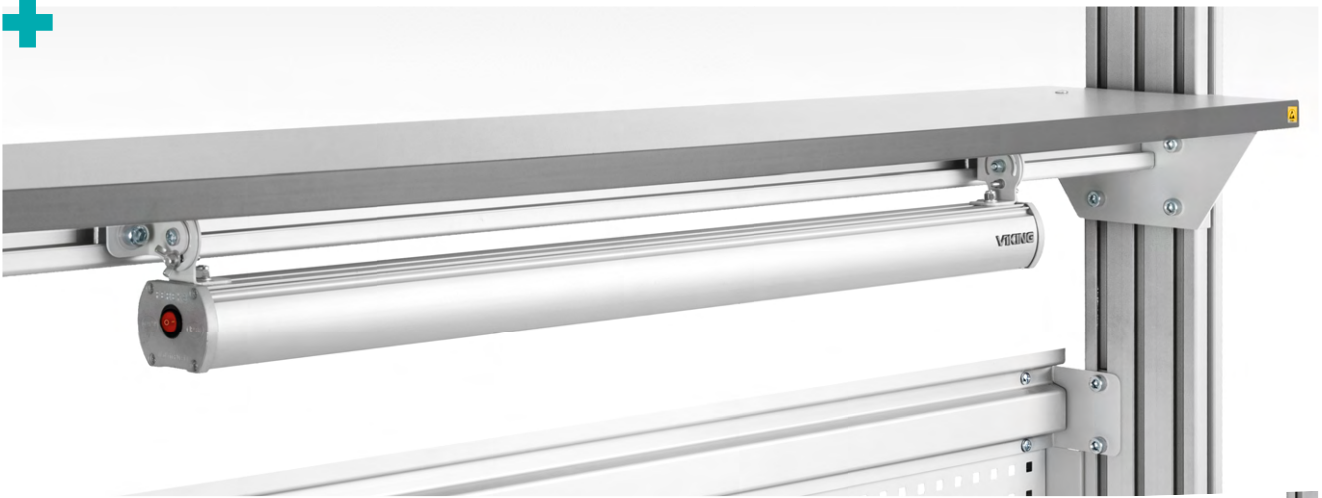

Additional local LED lighting can be mounted to any workbench series Main shelf and Perforated panel

- 2 versions: 60 cm length and 90 cm length
- Angle adjustment 120°



### PPT-01 Movable drawer unit support



Movable drawer unit support is an additional unit that helps to turn stationary drawer units and cabinets into movable one. It matches all standard cabinets (TMB-01 and TMB-02) and drawer units (DR-03, DR-05, DR-07 and DR-10/1). Four 50 mm casters, 2 of which are with brakes.

- Dimensions (W\*H\*D): 510x10x600 mm
- Load capacity: 350 kg



PO-ZHL-12/15/18 Sliding shutters shelf

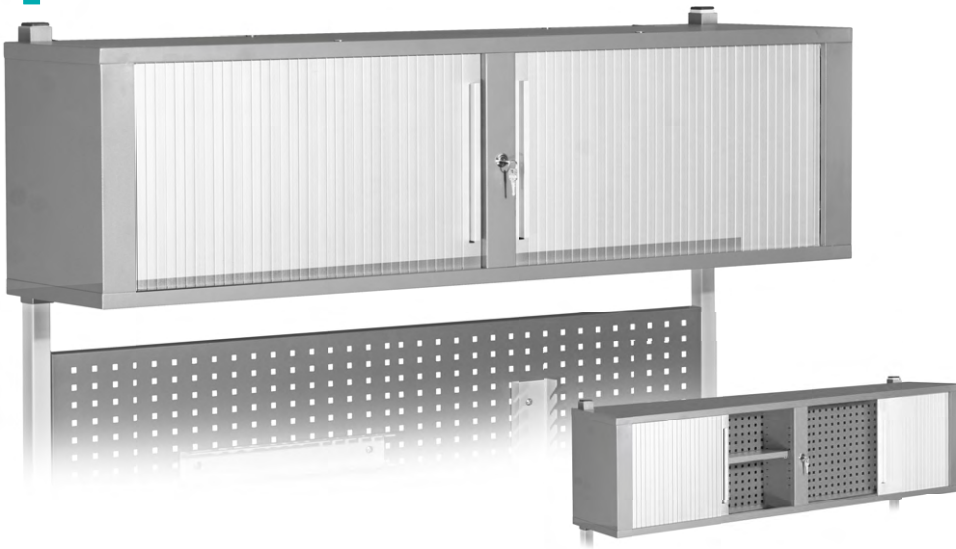

**Additional** shelf with sliding shutters can be mounted to any SR and VR series standard workbench which has Rear Racks. Additional shelf has two sliding shutters and a lock, which allows safe tools, equipment and documents storage.

PO-ZHL Sliding shelf is produced in 3 standard sizes to match 1200 mm, 1500 mm and 1800 mm workbenches.

- Dimensions (W\*H\*D):  
1200/1500/1800x400x300 mm
- Load capacity: 50 kg

PFP Perforated Panel accessories



	<p><b>K-01</b></p> <p>Hook for tweezers and equipment with small handles.</p> <p>Dimensions: 182x47x35 mm.</p>		<p><b>K-06</b></p> <p>Hooks for spanners.</p> <p>Dimensions: 150x190x45 mm</p>
	<p><b>K-02</b></p> <p>Hook for screwdrivers.</p> <p>Dimensions: 182x47x35 mm.</p>		<p><b>K-07</b></p> <p>Double hook for heavy instruments.</p> <p>Dimensions: 35x40x80 mm</p>
	<p><b>K-03</b></p> <p>Holder for pliers.</p> <p>Dimensions: 182x130x45 mm</p>		<p><b>K-08</b></p> <p>Tray for small components and bottles.</p> <p>Dimensions: 180x45x80 mm</p>
	<p><b>K-04</b></p> <p>Hook for tools.</p> <p>Dimensions: 182x45x23 mm</p>		<p><b>K-09</b></p> <p>Tray for A4-size papers.</p> <p>Dimensions: 310x45x220 mm</p>
	<p><b>K-05</b></p> <p>Holder for screwdrivers and 9-13 mm diameter drills.</p> <p>Dimensions: 180x100x30 mm</p>		<p><b>K-10</b></p> <p>A4-size papers holder.</p> <p>Dimensions: 240x280x25 mm.</p>

# ANTISTATIC EQUIPMENT VKG TOOLS

VKG A-9400 Connecting plug for grounding cables



White connecting plug for grounding cables with 1 MOhm resistor

VKG G-01 Universal grounding unit



Universal grounding unit compatible with most popular wrist strap connections : banana plug, GSGS, 4, 4.5, 7 and 10 mm snaps

- Grounds up to two single wrist straps
- 3 meter cord with eyelet
- No resistor

Should be mounted underneath tabletop and devices via junction block.

VKG A-3146 Grounding unit



Two 10 mm buttons ground table mats, wrist straps and devices via junction block.

ESD Wrist straps



VKG KH 4060, VKG KH 6090, VKG KH 12060 ESD mats



Fire-resistant and solder-resistant ESD mats. Supplied in a set with grounding cord and wrist strap.

- Antiglare matte surface
- Colors: blue, grey

**VKG A-2202** conductive fabric wrist strap with 4 mm button and a 4 mm – 10 mm cord

**VKG A-2202-0** conductive fabric wrist strap with 4 mm button

**VKG A-2210** conductive metal wrist strap with 4 mm button and a 4 mm – 10 mm cord

**VKG A-2210-0** conductive metal wrist strap with 4 mm button

CODE →	VKG KH 4060	VKG KH 6090	VKG KH 12060
Dimensions	400x600 mm	600x900 mm	1200x600 mm
Charge decay time	Less than 0,04 sec		
Typical resistance to ground	10 <sup>5</sup> ...10 <sup>9</sup> Ohm		



## TEST AND MEASUREMENT EQUIPMENT



**1** VKG A-750 Wrist straps and footwear tester

VKG A-750 is used for wrist straps and footwear antistatic testing on a daily basis. A person steps on a metal plate and attaches wrist strap's grounding cord to a connector. By pressing a metal button on a tester the person checks straps and footwear resistance functionality. Should resistances be within IEC 61340 acceptable range, a green indicator switches on; otherwise - a red one.

- Test voltage: 24 V
- Measurement range:
  - 750 kOhm - 10 MOhm (wrist strap)
  - 750 kOhm - 35 MOhm (footwear)

**2** VKG A-755 Calibrator for VKG A-750

VKG A-755 calibrator is used for periodic (on a quarterly basis and after batteries change) verification of VKG A-750 testers. The device is designed for quick and easy determination whether a tester is operable. Complies with IEC 61340 standards.

**3** VKG A-770 Temperature, humidity and surface resistance universal tester

VKG A-770 combines 3 measuring devices: thermometer, hygrometer and ohmmeter. For point to point and point to ground resistance 2 measuring electrodes and 2 m cords are used. The device is capable of recording 100 results in an energy-independent memory. They can be viewed either on a display or transferred by USB on a monitor.

Power supply can be provided by accumulators or by mains adapter; in the latter case, accumulators are automatically being recharged.

- Test voltage:
  - 10 V
  - 100 V
- Measuring range
  - at 10 V: 1 kOhm - 1 MOhm
  - at 100 V: 1 MOhm - 999 GOhm
- Relative humidity measuring range: 0 - 98%
- Temperature measuring range:
  - 0...+70 °C
  - - 40...+ 123 °C (with remote adapter)
- Accuracy in ranges:
  - 2.5% with less than 10 GOhm value
  - 5% up to 100 GOhm,
  - 10% when more than 100 GOhm
- Relative humidity measurement accuracy: ±3%
- Temperature measurement accuracy: ±0.5 °C
- Dimensions: 315x130x60 mm
- Weight: 700 g

## DRAWER UNITS



Steel frame drawer units are designed for tools and components storage. Movable and stationary drawer units can be also used as additional workplaces. Steel frame drawer units are equipped with central lock and either 550 mm telescoping drawers or shelves. Movable units have 4 rubber casters, 2 of which are with [brakes](#).

Drawers' inner dimensions for different types are

**A** – 400x45x505 mm **B** – 400x100x505 mm **C** – 400x160x505 mm. Load capacity per drawer 30 kg

### Suspended and movable drawer units

DRAWER UNITS ↴	SUSPENDED		MOVABLE	
	TP-01/P	TP-02/P	TP-01/S	TP-02
Picture number	<b>1</b>	<b>2</b>	<b>3</b>	<b>4</b>
Dimensions (W*H*D):	490x354x580 mm	490x233x580 mm	490x580x580 mm	490x650x580 mm
Quantity of drawers	3	2	3	4
Drawers per unit	<b>A</b>	1	–	1
	<b>B</b>	2	1	2
	<b>C</b>	–	–	1
Weight (kg)	20	15	25	32

When ordering, please, mention whether ESD or technical version, and whether dark grey RAL 7012 or light grey RAL 7035 color required.



Stationary cabinets and drawer units

Steel frame stationary cabinets and drawer units are designed for tools and components storage and can be also used as additional work-places. All stationary cabinets and drawer units can be installed as worktop supports for Constant series workbenches and Verstak series heavy duty workbenches. All standard stationary cabinets and drawer units are bicolored by default.

CABINETS AND DRAWER UNITS ↴		STATIONARY CABINETS AND DRAWER UNITS			
		TMB-01	TMB-02	DR-03/1	DR-05/1
Picture number		5	6	7	8
Dimensions (W*H*D):		500x800x590 mm	500x800x590 mm	500x800x590 mm	500x800x590 mm
Quantity of drawers		2 shelves	1	3	5
Drawers per unit	B	-	1	-	4
	C	-	-	3	1
Weight (kg)		25	30	35	40

When ordering, please, mention whether ESD or technical version required.

## ENLARGED CABINETS AND DRAWER UNITS

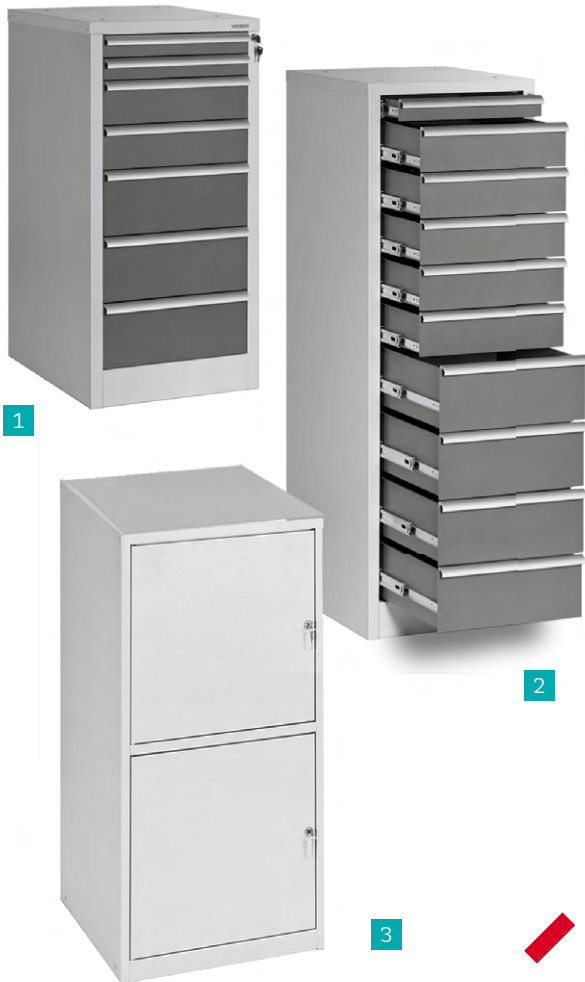

## ADDITIONAL EQUIPMENT FOR DRAWERS

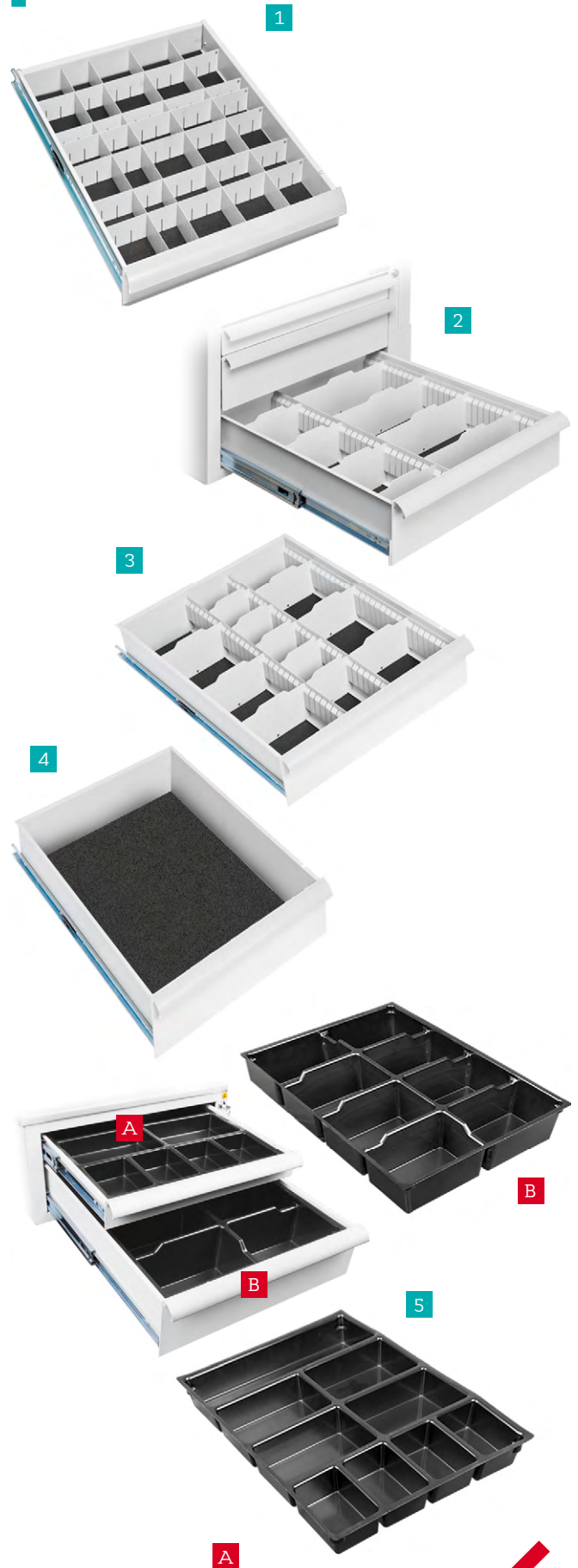

**Steel** frame enlarged stationary drawer units are designed for tools and components storage; can be also used as additional workplaces.

DR-07/1 and DR-10/1 enlarged stationary drawer units are bicolored by default. For TMB-03 cabinet, please, mention whether dark grey RAL 7012 or light grey RAL 7035 color required.

**Drawers'** inner dimensions for different types are

**A** – 400x45x505 mm **B** – 400x100x505 mm **C** – 400x160x505 mm.

	DR-07/1	DR-10/1	TMB-03
Picture number	<b>1</b>	<b>2</b>	<b>3</b>
Dimensions (W*H*D):	500x1040x x590 mm	500x1520x x590 mm	540x1050x x500 mm
Quantity of drawers	7	10	2 closable sections
Drawers types per unit	<b>A</b>	2	1
	<b>B</b>	2	5
	<b>C</b>	3	4
Weight (kg)	55	75	20

## ALPHA CABINET

### Drawer dividers sets

**Dividers** help to organize drawer internal space according to specific needs.

**One** can modify the space to many cells according to the number and dimensions of items needed to store: instruments, PCBs, mounting elements or other **items**.

#### 1 D-10/A

**Dividers** for type A drawers (400x45x505 mm). The set consists of 4 longitudinal and 6 transversal dividers. Up to 35 different sized cells can be **organized**.

#### 2 D-11/B

**Dividers** for type B drawers (400x100x505 mm). The set consists of 3 longitudinal and 4 big and 4 small profiled transversal dividers. Up to 10 different sized cells can be **organized**.

#### 3 D-16/B

**Dividers** for type B drawers (400x100x505 mm). The set consists of 4 longitudinal and 6 medium and 6 small profiled transversal dividers. Up to 15 different sized cells can be **organized**.

#### 4 KD/AB mat

**ESD** mat that should be ordered separately if drawers dividers set is being ordered for technical version cabinets. KD/AB mat is necessary to provide drawers dividers set stability and **reliability**.

#### 5 Additional equipment for drawers – plastic ESD trays

**ESD** inserts for components and personal belongings convenience storage are made to match standard type A and type B drawers. ESD inserts are produced of 2,2 mm thick black dissipative polystyrene. Max temperature **60°C**.

2 versions:

- **V-01 ESD**, Antistatic inserts for type **A** standard drawers (400x45x505 mm). Insert contains 9 different shape and dimensions cells: one 375x112 mm cell, four 182x112 mm cells, and four 86x112 mm cells.
- **V-02 ESD**, Antistatic inserts for type **B** standard drawers (400x100x505 mm). Insert contains 8 similar dimensions cells 112x182 mm each.

### ALF-TMB-02 cabinet



**Spacious** metal cabinet for documents, folders and personal belongings; can be attached to workbench by bolts. Cabinet has 2 standard drawers and 2 sliding shelves, each has a perforated side wall, which can be placed on right or left side depending on further **usage**.

- Dimensions: 445x1285x700 mm
- Distributed load capacity of each shelf: 30 kg
- Can be attached to any ALPHA series workbench from either side.



### Shelves dividers for ALF-TMB-02 cabinet

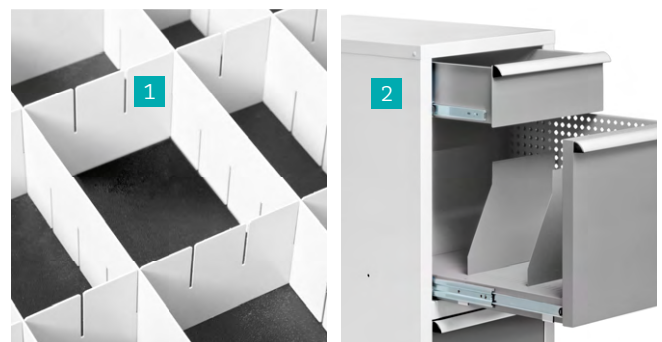

#### 1 D-7/ALF Horizontal dividers

- 7 horizontal 335 mm length dividers help to organize cells for different small items.

#### 2 D-4/ALF Vertical dividers

- 4 vertical 240 x 290 mm dividers help to organize slots for folders and documents.



## MOVABLE TABLES AND CARTS



1 PS-07 Comfort

2 3 4 PS-07, PS-10, PS-15 movable tables

Movable tables are used for tools and components storage and transportation. All movable tables are equipped with four 75 mm casters, 2 of which are with brakes. Height adjustment: 650 - 950 mm.

CODE	PS-07 COMFORT	PS-07	PS-10	PS-15
Picture number	1	2	3	4
Load capacity per surface (kg)	100 kg		150 kg	
Dimensions (W*D):	710x515 mm		700x1000 mm	700x1500 mm

5 AL-PS Alliance Movable table

Movable table is used for tools and components storage and transportation. Equipped with four 75 mm casters, 2 of which are with brakes.

- 3 shelves with heights adjustment
- Dimensions (W\*H\*D): 690 x 840 x 460 mm
- Load capacity: 150 kg.

When ordering, please, mention whether ESD or technical version, and whether dark grey RAL 7012 or light grey RAL 7035 color required.



6 7 8 TT-02, TT-03, TT-04 transportation carts

Transportation carts are used for tools and components storage and transportation.

Metal carts are equipped with four 75 mm (for TT-02, TT-03 carts) or 125 mm (for TT-04 cart) casters, 2 of which are with brakes, and height adjustable shelves.

CODE	TT-02	TT-03	TT-04
Picture number	6	7	8
Dimensions (W*H*D):	470×990×840 mm	470×990×840 mm	615×1560×1270 mm
Quantity of shelves	2	3	4
Shelves height adjustment	140 – 800 mm	140 – 800 mm	190 – 1480 mm
Load capacity (kg)	100 kg	100 kg	100 kg

When ordering, please, mention whether ESD or technical version, and whether dark grey RAL 7012 or light grey RAL 7035 color required.



## MOVABLE TROLLEYS



1 ST-05 Movable trolley      2 ST-05 Comfort Movable trolley

Movable trolleys are used for tools and components storage and transportation.

- 5 height-adjustable shelves and power panel with 5 grounded and 1 ungrounded sockets
- Lateral position of power panel
- 2 of 4 casters are with brakes
- Total load capacity: 150 kg

CODE	ST-05	ST-05 COMFORT
Dimensions (W*H*D):	500x1600x600 mm	460x1600x680 mm

3 ST-06 Movable trolley

Movable trolley is used for tools and components storage and transportation.

- 5 height-adjustable shelves
- 2 of 4 casters are with brakes.
- Dimensions (W\*H\*D): 500x1605x600 mm
- Total load capacity: 150 kg

4 AL-ST Equipment trolley

Equipment trolley is designed for additional equipment storage and transportation. It has 5 height adjustable shelves and a power panel with 4 sockets and a switch. The panel is located on the side frame thus does not occupy any space on shelves. Equipment trolley side frames are manufactured of aluminum profile, which allows attaching small elements, and gives the whole unit elegant look. Trolley has 4 casters, 2 of which are with brakes as supports.

- Dimensions (W\*H\*D): 690x1940x460 mm.
- Load capacity: 150 kg

When ordering, please, mention whether ESD or technical version, and whether dark grey RAL 7012 or light grey RAL 7035 color required.





5

6

7

8

#### 5 SKM Dual movable trolley

**Dual** Movable trolley for accessories is made of a rack coated with conductive powder paint, thus available only in ESD version. Lower shelf made of ESD laminated chipboard 25 mm thick. Trolley is equipped with four 75 mm casters (2 of them with brakes) and six rails for boxes. Attachable bins are ordered [separately](#).

- Load capacity: 100 kg
- Dimensions (W\*H\*D): 680 x 1600 x 460 mm

#### 6 ST-R Movable repairing trolley

**The** trolley is equipped with 2 perforated panels in the upper part and a drawer unit with 5 telescoping drawers [lower](#).

- Dimensions:
  - Trolley dimensions (W\*H\*D): 600x1730x630 mm
  - Drawer unit dimensions (W\*H\*D): 500 x 800 x 590 mm
  - Perforated panels dimensions (W\*H): 525x600 mm
- Perforated panel load capacity: 10 kg

#### 7 ST-VR Movable equipment trolley

**Convenient** equipment trolley with side handle allows tools and equipment storage on upper perforated panel and two lower shelves. All standard hooks (K-01 – K10) can be mounted to upper perforated panel. Movable trolley equipped with four casters, all with [brakes](#).

- Dimensions(W\*H\*D): 800x1600x690 mm
- Load capacity per shelf: 100 kg
- Trolley load capacity: 250 kg

#### 8 SUS Movable packing trolley

**Auxiliary** trolley, designed for convenient polyethylene, damping film, paper and other packaging materials rolls clamping; maximum roll's width - 1.5 m. Movable packing trolley equipped with four 50 mm casters, all with [brakes](#).

- Dimensions (W\*H\*D): 1800x1240x600 mm
- Load capacity: 10 kg

When ordering, please, mention whether ESD or technical version, and whether dark grey RAL 7012 or light grey RAL 7035 color required.

CABINETS AND WARDROBES



Cabinets and wardrobes

All cabinets have central lock.

Most models have 3 or 4 height adjustable shelves with 50 mm pitches.

For wardrobe and combined cabinets garment bar included.  
 For SHDZH Sliding shutters cabinets inner dividers included.  
 For SHKH cabinets 16 (SHKH-2) to 30 (SHKH-1) 360 mm telescoping drawers included.

- Drawers dimensions 310x100x370 mm.
- Load capacity per surface - 30 kg.

PICTURE NUMBER		DIMENSIONS (W*H*D), MM	WEIGHT, KG
SHD-1, SHD-2 Filing cabinets			
1a	SHD-1	1000x1950x550	80
	SHD-2	820x1850x450	62
1b	SHD-3	820x1000x450	40
SHO-1, SHO-2 Wardrobe cabinets			
2	SHO-1	1000x1950x550	68
	SHO-2	820x1850x450	52

When ordering, please, mention whether ESD or technical version, and whether dark grey RAL 7012 or light grey RAL 7035 color required.



4

5

PICTURE NUMBER		DIMENSIONS (W*H*D), MM	WEIGHT, KG
	SHK-1, SHK-2 Combined cabinets		
3	SHK-1	1000x1950x550	78
	SHK-2	820x1850x450	58
	SHKH-1, SHKH-2 Drawers cabinets		
4	SHKH-1	820x1850x450	127
	SHKH-2	820x1060x450	69

#### Shelves dividers for SHKH cabinets

5 D-6/SH

**Dividers** for type SHKH drawers (360x100x310 mm). The set consists of 2 longitudinal and 4 transversal dividers. Up to 15 different sized cells can be [organized](#).

6 KD/SH mat

**ESD** mat that should be ordered separately if drawers dividers set is being ordered for technical version cabinets. KD/SH mat is necessary to provide drawers dividers set stability and [reliability](#).

When ordering, please, mention whether ESD or technical version, and whether dark grey RAL 7012 or light grey RAL 7035 color required.

SLIDING SHUTTERS CABINETS



1 SHDZH-1 Sliding shutters cabinet

2 SHDZH-2 Sliding shutters cabinet

**SHDZH-1** Sliding shutters cabinet is a compact metal cabinet with two sliding shutters and a lock in the middle. Each section equipped with 2 shelves and inner dividers to provide convenient documents storage.

- Load capacity per shelf- 50 kg
- Dimensions (W\*H\*D): 615x1700x400 mm

**SHDZH-2** Sliding shutters cabinet is a metal cabinet with sliding shutters upper section and standard metal lower section. Upper sliding shutters section is equipped with 2 shelves and inner dividers to provide convenient documents storage. Lower section has 2 standard shelves and metal doors with a lock.

- Load capacity per shelf- 50 kg
- Dimensions (W\*H\*D): 1000x1850x450 mm

# SHELVING



1

2

3

## STU Shelving

Shelving is used for documents and components storage. Shelving (except for the STU-01) have height-adjustable supports and 5 height adjustable shelves with 50 mm pitches.

For STU-01 there are 6 height adjustable shelves with 50 mm pitches.

- Load capacity per shelf - 30 kg.
- Load capacity total:
  - 180 kg for STU-01,
  - 110 kg - for STU-02, STU- 03, STU-04, STU-05.

PICTURE NUMBER	DIMENSIONS (W*H*D), MM	
1	STU-01	820x1850x430
	STU-02	820x1850x430
2	STU-03	1000x1850x530
	STU-04	820x1950x430
	STU-05	1000x1950x530

## STS Reinforced shelving

Height-adjustable supports. 4 height adjustable shelves with 50 mm pitches. No additional floor leveling required

- Load capacity per shelf - 200 kg.
- Load capacity total - 640 kg.

PICTURE NUMBER	DIMENSIONS (W*H*D), MM	
3	STS-12	1200x1800x600
	STS-15	1500x1800x600

## PL-1, PL-2, PL-ST5-12, PL-ST5-15 Additional shelves

Additional shelves for cabinets and shelving

SHELVES	SHOULD BE USED FOR
PL-1	SHD-1, STU-03, STU-05
PL-2	SHD-2, SHD-3, STU-01, STU-02, STU-04
PO-ST5-12	STS-12
PO-ST5-15	STS-15

When ordering, please, mention whether ESD or technical version, and whether dark grey RAL 7012 or light grey RAL 7035 color required.

ESD CHAIRS

VKG C-100 ESD



ESD laboratory chair, covered with static dissipative fabric, can be equipped with five conductive glides or five ESD casters. Can be also equipped with ESD armrests, footrest and enlarged gaslift on [request](#).

- Back angle adjustment
- Seat height adjustment: 43 - 63 cm
- Resistance: less than 1 MOhm
- Weight: 7 kg
- Available colors: grey and blue

VKG C-200 ESD



ESD laboratory chair, covered with static dissipative fabric, can be equipped with five conductive glides or five ESD casters. Can be also equipped with ESD armrests, footrest and enlarged gaslift on [request](#).

- Back and seat angles adjustments
- Seat height adjustment: 43 - 63 cm
- Resistance: less than 1 MOhm
- Weight: 7,5 kg
- Available colors: grey and blue

VKG C-300 ESD



ESD laboratory chair with conductive incombustible polyurethane upholstery can be equipped with five conductive glides or five ESD casters. Can be also equipped with ESD armrests, footrest and enlarged gaslift on [request](#).

- Back angle adjustments
- Seat height adjustment: 43 - 57 cm
- Resistance: less than 1 MOhm
- Weight: 7,5 kg
- Cleanroom - suitable.

VKG C-400 ESD



ESD laboratory stool with conductive incombustible polyurethane upholstery can be equipped with five conductive glides or five ESD casters. Can be also equipped with ESD footrest and enlarged gaslift on [request](#).

- Seat height adjustment: 43 - 63 cm
- Resistance: less than 1 MOhm
- Weight: 4 kg
- Cleanroom - suitable.

Please, when ordering chair/stool, mention necessary gaslift type.

VKG F-05 ESD glides



A set of 5 ESD glides may be ordered for all types of ESD chairs and ESD stool.

P607A ESD casters



A set of 5 ESD casters may be ordered for all types of ESD chairs and ESD stool.

KT ESD armrests



A set of ESD armrests can be additionally ordered for all types of ESD chairs.

Gaslifts

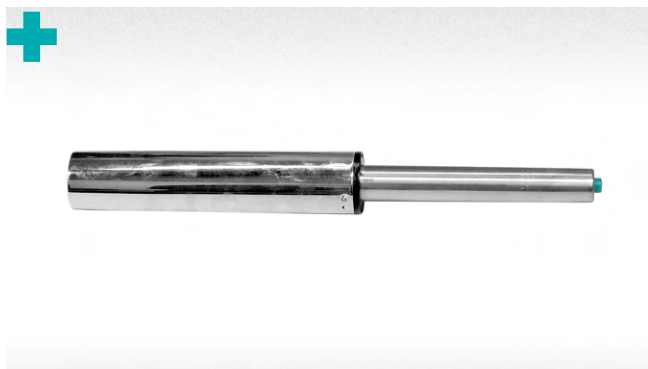

Foot ring (support)



ESD chairs and armchairs originally equipped by KJ/200 gaslift, which allows to adjust seat height 43-63 cm from the floor. KJ/200 and KJ/260 gaslifts can be ordered separately.

Height-adjustable supportive foot ring. Recommended for chairs with extended gaslifts.

CASTER TYPE	SEAT HEIGHT ADJUSTMENT
KJ/200	43 -63 cm
KJ/260	54- 83 cm

RING TYPE	RING DIAMETER
JR-430	43 cm
JR-600	60 cm

## ESD GARMENTS

ESD garments shield external objects from electrostatic discharge, which is generated on internal garments by friction.

VA Unisex Shortcut lab coat

VAE-M Men's lab coat, VAE-W Women's lab coat



- Machine washable at 60 °C
- At least 50 washing cycles without losing ESD characteristics
- Charge decay time: < 0.17 s
- Composition:
  - 66% polyester
  - 33% cotton
  - 1% grounding fibers
- Colors: white, blue

- Machine washable at 60 °C
- At least 50 washing cycles without losing ESD characteristics
- Charge decay time: < 0.17 s
- Composition:
  - 66% polyester
  - 33% cotton
  - 1% grounding fibers

VH-01 Antistatic bandana



Material:

- 66% polyester
- 33% cotton
- 1% conductive fibers

Colors:

- blue
- white



When ordering, mention necessary height (152-194 mm) and size (EUR 34-54).

VAK-M Men's costume, VAK-W Women's costume



- Machine washable at 60 °C
- At least 50 washing cycles without losing ESD characteristics
- Charge decay time: < 0.17 s
- Composition:
  - 66% polyester
  - 33% cotton
  - 1% grounding fibers
- Colors: white, blue, white and blue combined

VAT-W Women's trousers VAT-M men's trousers



- Machine washable at 60 °C
- At least 50 washing cycles without losing ESD characteristics
- Charge decay time: < 0,17 s
- Composition:
  - 66% polyester
  - 33% cotton
  - 1% grounding fibers
- Colors: white, blue

VH-02 Antistatic cap

### Material:

- 66% polyester
- 33% cotton
- 1% conductive fibers

### Colors:

- blue
- white

### Sizes:

- 54-62

### Elastic band



## OUR CUSTOMERS

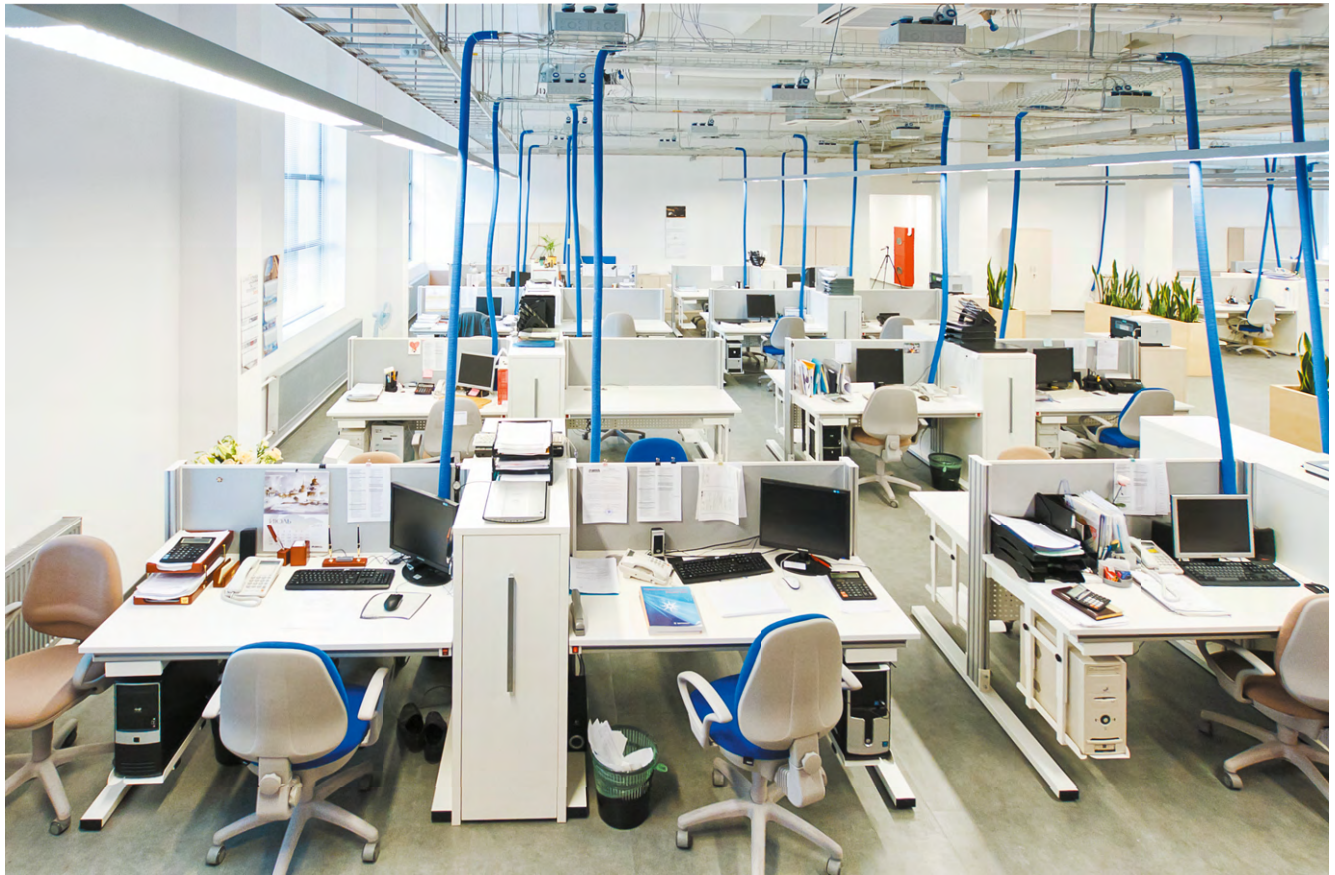



**TECHNICAL & ESD FURNITURE  
ANTISTATIC EQUIPMENT**

**VIKING VKG TOOLS**



 **DIPPAUL**

PLZENSKA 155/113  
150 00 PRAGUE 5  
CZECH REPUBLIC  
TEL: +420 2 5573 9633  
E-MAIL: [INFO@DIPPAUL.EU](mailto:INFO@DIPPAUL.EU)